

# Data Sheet : SSL502



Intertek



Electrical & Lighting Products

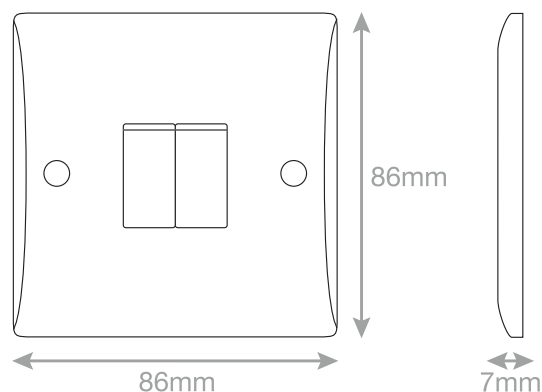

<b>Code</b>	SSL502
<b>Description</b>	10 Amp Plate Switch - 2 Gang 2 Way - X-Rated
<b>Size</b>	86mm x 86mm x 7mm depth
<b>Range</b>	Selectric Smooth
<b>Colour</b>	White
<b>Material</b>	Bakelite
<b>Included</b>	M3.5 fixing screws & white blanking caps
<b>Weight</b>	0.07kg
<b>Inner Carton Quantity</b>	10
<b>Inner Carton Weight</b>	0.7kg
<b>Guarantee</b>	30 years
<b>Barcode</b>	5025117986028
<b>Commodity Code</b>	85369085
<b>Standards</b>	BS EN 60669-1
<b>Notes</b>	<ul style="list-style-type: none"><li>• ASTA approved</li><li>• X-rated for fluorescent or inductive loads</li><li>• Modular and Euro Media products available within the range</li><li>• Minimum back box size required: 16mm depth</li></ul>